

TCD 2013

The Gen Engine.
250 – 263 kW at 1500/1800 rpm

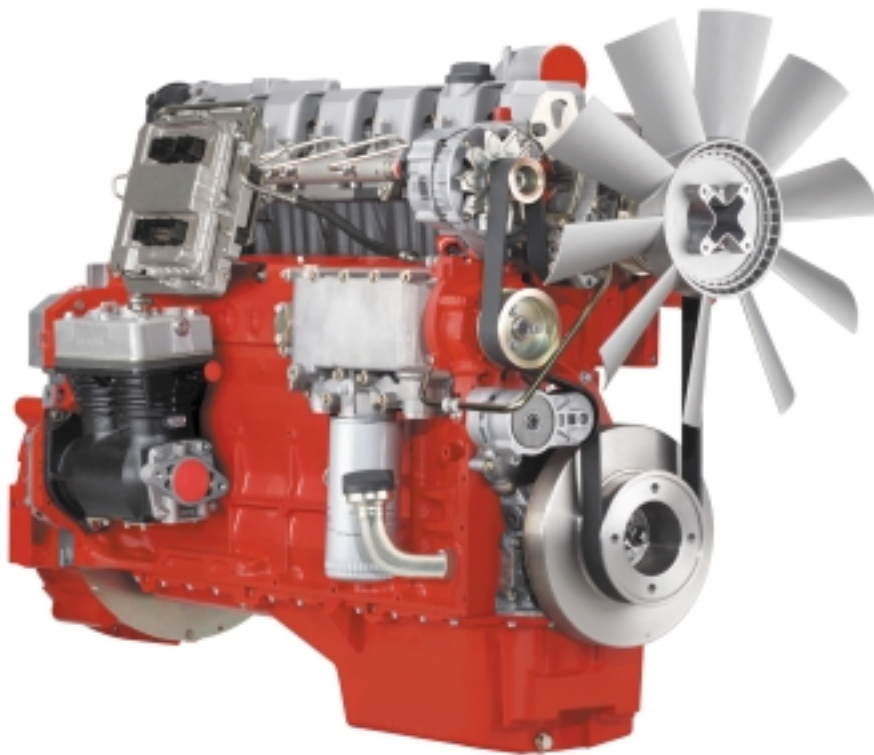

The engine company.



Engine description

Engine:	4 stroke diesel engine with direct injection.
Turning direction:	At flywheel side to the left.
Cylinder configuration:	Standing in line.
Crankcase/cylinder:	Crankcase of grey cast iron, wet liners.
Cylinder head:	Greycast block type cylinder head.
Valve arrangement/timing:	Hanging in cylinder head, two intake and exhaust valves each, actuated via tappets, pushrods and rocker arms, driven by camshaft in bi-metal bearings.
Camshaft drive:	From the camshaft via straight, high toothed spur gears.
Crankshaft bearings:	Tri-metal bearings.
Connecting rod bearings:	Four-metal, tri-metal sliding bearing.
Turbocharging:	Wastegate turbocharger with charge air cooling (air/air).
Lubrication:	Forced-feed circulation lubrication.
Lubricating oil filter:	One microfilter in full-flow.
Injection pump:	Two high-pressure plug pumps.
Injector:	7-hole nozzle in Injector.
Governor:	Electronical speed governor (EMR3).
Fuel lift pump:	Gear driven gear pump.

Characteristics

Modern, liquid-cooled 6-cylinder in-line engines | Turbocharged with intercooler | Powerful, rugged engine providing high power density | Electronic engine control EMR 3 | High-pressure fuel injection with DEUTZ Common Rail System (DCR®)

Your benefits

- Low noise emission: Lower costs for sound deadening.
- Low fuel and oil consumption and long service intervals save operating cost.
- Very good load characteristics.
- Simple and cost efficient installation due to low weight and small installation space requirements.
- Low exhaust emissions, meets EC regulation step II.

Engine type

		TCD 2013 L6 4V	
Number of cylinders		6	
Bore/stroke	mm	108/130	
Displacement	l	7.15	
Compression ratio		1 : 18.1	
Weight incl. cooling system and air filter	kg	955	

	50 Hz 1500 rpm	60 Hz 1800 rpm
--	-------------------	-------------------

Power output LTP ¹⁾

Gross output	kW HP	250 336	263 354
Flywheel net	kW HP	238 320	243 327

Fuel consumption ²⁾

25 % load	g/kWh lb/hp-hr	233 0.383	254 0.417
50 % load	g/kWh lb/hp-hr	229 0.376	241 0.396
75 % load	g/kWh lb/hp-hr	213 0.350	225 0.369
100 % load	g/kWh lb/hp-hr	200 0.328	206 0.338

Cooling system/heating balance

Water cooler	kW HP	122 164	130 175
Chargeair cooler	kW HP	48 65	57 77
Convection	kW HP	25 34	26 35
Fan power	kW HP	12 16	20 27
Cooling air volume flow	m ³ /h	16200	21240

Combustion air/emissions

max. intake vacuum	mbar	30	30
Combustion air volume flow	m ³ /h	909	1027
max. exhaust gas temperature	°C	530	490
Exhaust gas volume flow	m ³ /h	2550	2740

Dimensions

	A	B	C
TCD 2013 L6 4V mm	1865	1057	1315
inch	73.4	41.6	51.8

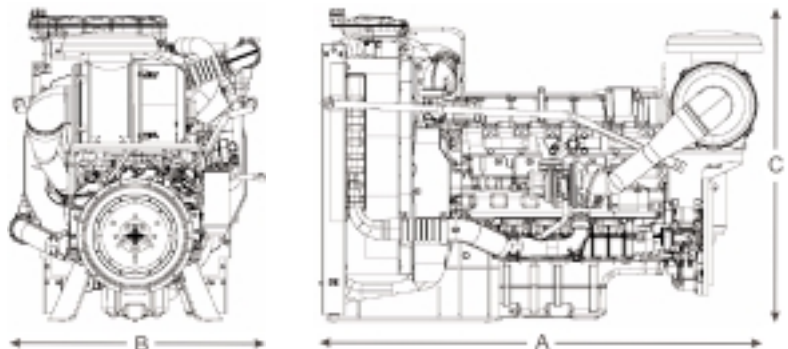

1) Power ratings acc. to ISO 8528, rating category G3 acc. to ISO 8528-5

2) based on diesel fuel with a specific gravity of 0.835 kg/dm³ at 15° C (6.96 lb/US gallon at 60° F).

The values specified in this datasheet are for information-purposes only and are not binding. The information given in the quotation is decisive.

